

# Trusted Power Distribution Unit 15-Way Fused

## Product Overview

The Trusted® Power Distribution Unit 15-way Fused provides 15 dual redundant fused power outputs from dual redundant 24 Vdc or 48 Vdc incoming power feeders. The Unit is designed to be mounted on a DIN rail.

On-board monitoring circuits provide local Light Emitting Diode (LED) indication of individual fuse failure (red LED). A common fuse failure alarm signal is provided by the Unit via a volt-free relay contact output.

## Features:

- Fifteen 'dual' 24 Vdc or 48 Vdc, 3.15 A fuse protected outputs – suitable for direct connection to Trusted Field Termination Assemblies (FTAs), or other equipment.
- Visual indications of input power supply status.
- Visual indication of individual fuse status.
- Common alarm of fuse status via volt-free contact.
- Link selectable supply voltage options.

Page intentionally left blank

## PREFACE

In no event will Rockwell Automation be responsible or liable for indirect or consequential damages resulting from the use or application of this equipment. The examples given in this manual are included solely for illustrative purposes. Because of the many variables and requirements related to any particular installation, Rockwell Automation does not assume responsibility or reliability for actual use based on the examples and diagrams.

No patent liability is assumed by Rockwell Automation, with respect to use of information, circuits, equipment, or software described in this manual.

All trademarks are acknowledged.

### DISCLAIMER

It is not intended that the information in this publication covers every possible detail about the construction, operation, or maintenance of a control system installation. You should also refer to your own local (or supplied) system safety manual, installation and operator/maintenance manuals.

### REVISION AND UPDATING POLICY

This document is based on information available at the time of its publication. The document contents are subject to change from time to time. The latest versions of the manuals are available at the Rockwell Automation Literature Library under "Product Information" information "Critical Process Control & Safety Systems".

### TRUSTED RELEASE

This technical manual applies to **Trusted Release: 3.6.1**.

### LATEST PRODUCT INFORMATION

For the latest information about this product review the Product Notifications and Technical Notes issued by technical support. Product Notifications and product support are available at the Rockwell Automation Support Centre at <http://rockwellautomation.custhelp.com>

At the Search Knowledgebase tab select the option "By Product" then scroll down and select the Trusted product.

Some of the Answer ID's in the Knowledge Base require a TechConnect Support Contract. For more information about TechConnect Support Contract Access Level and Features please click on the following link:

[https://rockwellautomation.custhelp.com/app/answers/detail/a\\_id/50871](https://rockwellautomation.custhelp.com/app/answers/detail/a_id/50871)

This will get you to the login page where you must enter your login details.

---

**IMPORTANT** A login is required to access the link. If you do not have an account then you can create one using the "Sign Up" link at the top right of the web page.

---

**DOCUMENTATION FEEDBACK**

Your comments help us to write better user documentation. If you discover an error, or have a suggestion on how to make this publication better, send your comment to our technical support group at <http://rockwellautomation.custhelp.com>

## SCOPE

This manual specifies the maintenance requirements and describes the procedures to assist troubleshooting and maintenance of a Trusted system.

## WHO SHOULD USE THIS MANUAL

This manual is for plant maintenance personnel who are experienced in the operation and maintenance of electronic equipment and are trained to work with safety systems.

## SYMBOLS

In this manual we will use these notices to tell you about safety considerations.



**SHOCK HAZARD:** Identifies an electrical shock hazard. If a warning label is fitted, it can be on or inside the equipment.



**WARNING:** Identifies information about practices or circumstances that can cause an explosion in a hazardous environment, which can cause injury or death, property damage or economic loss.



**ATTENTION:** Identifies information about practices or circumstances that can cause injury or death.



**CAUTION:** Identifies information about practices or circumstances that can cause property damage or economic loss.



**BURN HAZARD:** Identifies where a surface can reach dangerous temperatures. If a warning label is fitted, it can be on or inside the equipment.



This symbol identifies items which must be thought about and put in place when designing and assembling a Trusted controller for use in a Safety Instrumented Function (SIF). It appears extensively in the Trusted Safety Manual.

---

### IMPORTANT

Identifies information that is critical for successful application and understanding of the product.

---

### NOTE

Provides key information about the product or service.

---

### TIP

Tips give helpful information about using or setting up the equipment.

---

**WARNINGS AND CAUTIONS**

---

**WARNING: EXPLOSION RISK**

Do not connect or disconnect equipment while the circuit is live or unless the area is known to be free of ignitable concentrations or equivalent

---

**AVERTISSEMENT - RISQUE D'EXPLOSION**

Ne pas connecter ou déconnecter l'équipement alors qu'il est sous tension, sauf si l'environnement est exempt de concentrations inflammables ou équivalente

---

**MAINTENANCE**

Maintenance must be carried out only by qualified personnel. Failure to follow these instructions may result in personal injury.

---

**CAUTION: RADIO FREQUENCY INTERFERENCE**

Most electronic equipment is influenced by Radio Frequency Interference. Caution should be exercised with regard to the use of portable communications equipment around such equipment. Signs should be posted in the vicinity of the equipment cautioning against the use of portable communications equipment.

---

**CAUTION:**

The module PCBs contains static sensitive components. Static handling precautions must be observed. DO NOT touch exposed connector pins or attempt to dismantle a module.

---

**ISSUE RECORD**

<b>Issue</b>	<b>Date</b>	<b>Comments</b>
6	Sep 05	Format
7	Dec 06	Specifications
8	Jul 12	Correction
9	Sep 15	Rebranded and reformatted
10	Apr 16	Standardisation of Relative Humidity Range and Operating Temperature statements in the Specification Section

Page intentionally left blank

# Table of Contents

1.	Description .....	3
2.	Status Indicators .....	5
3.	Configuration .....	7
4.	Installation .....	9
5.	Associated Trusted Power Cables.....	11
6.	Terminal Connections .....	13
7.	Specifications.....	15

Page intentionally left blank

# 1. Description

The Trusted Power Distribution Unit 15-Way Fused is shown in Figure 1 below.

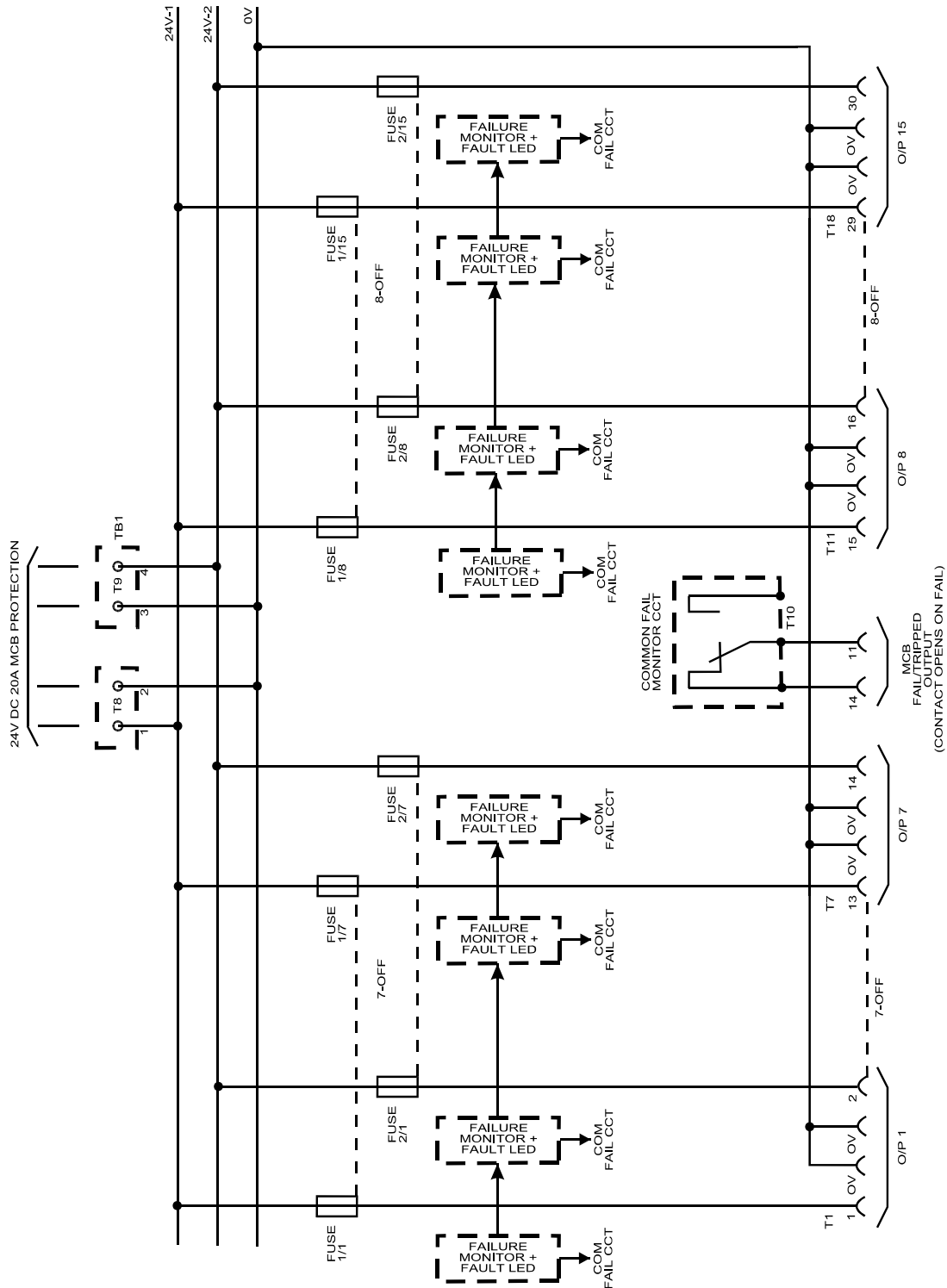

Figure 1 Trusted Power Distribution Unit 15-Way Fused

Two 24 Vdc or 48 Vdc (link selectable) supplies, are distributed through 30 fuses, arranged in two banks of 15 fuses. The outputs are fed via 15 terminal blocks labelled T1 to T7, and T11 to T18.

Each supply shares a common 0 V reference.

Each fuse is monitored for open circuit condition and provides a local on-board LED indication of individual fuse failure. Red LEDs are used to display the failed state.

A volt-free relay contact provides the fuse failure common alarm signal (contact open for fuse failure) for connection to external alarm monitoring circuits.

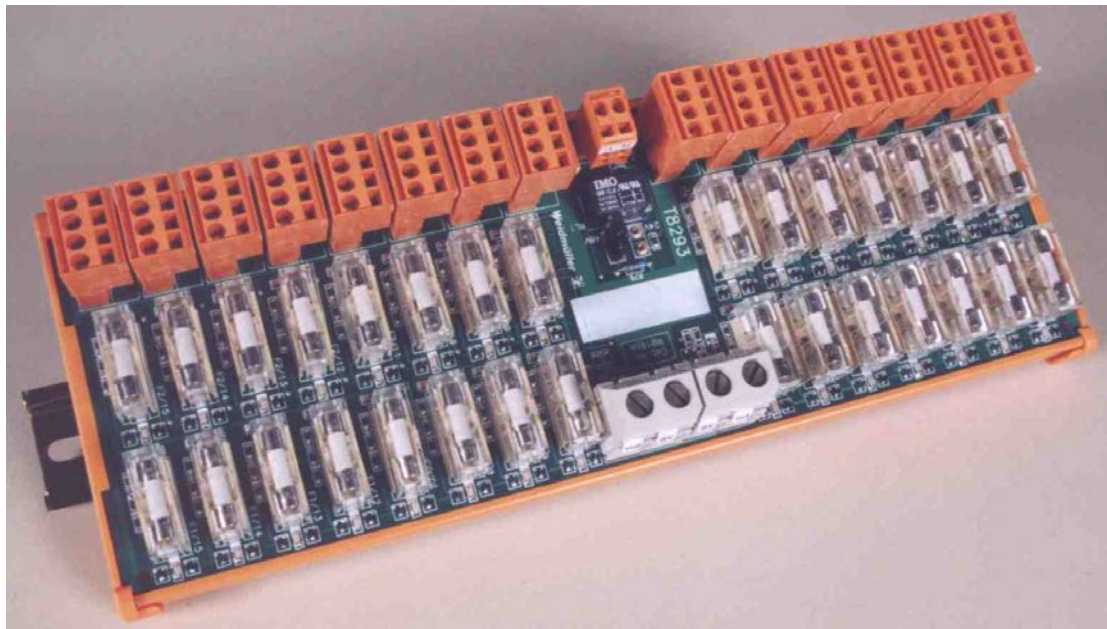

Figure 2 T8293 Photo

## 2. Status Indicators

2-off green LED	On to indicate that the associated power supply feeder is healthy.
30-off red LED	On to indicate that the adjacent fuse has failed.

Page intentionally left blank

## 3. Configuration

Link selection for 24 Vdc or 48 Vdc operation. The appropriate link must be fitted to select the required voltage.

Page intentionally left blank

## 4. Installation

The Trusted Power Distribution Unit 15-Way Fused may be mounted on either of the TS32 or TS35 DIN rails in the horizontal or vertical position as required.

Page intentionally left blank

## 5. Associated Trusted Power Cables

<b>Cable Type</b>	<b>Description</b>
TC-002-01	Interconnection Cable MCB Distribution Unit (T8292) to Fuse Distribution Unit (T8293)
TC-003-01	Interconnection Cable Fuse Distribution Unit (T8293) to I/P FTAs
TC-004-01	Power Cable Fuse Distribution Unit (T8293) to VFTA's Single Power Group

**Table 1 Associated Trusted Power Cables**

Page intentionally left blank

## 6. Terminal Connections

The terminal connections for the Trusted Power Distribution Unit 15-Way Fused are shown below.

Terminal	Description	Terminal	Description
T8-1	V+ – Incoming Supply 1	T8-2	0 V – Incoming Supply 1
T9-3	V+ – Incoming Supply 2	T9-4	0 V – Incoming Supply 2
T1-1	Output from Fuse 1/1	T1-0V	0 V associated with Fuse 1/1
T1-2	Output from Fuse 2/1	T1-0V	0 V associated with Fuse 2/1
T2-3	Output from Fuse 1/2	T2-0V	0 V associated with Fuse 1/2
T2-4	Output from Fuse 2/2	T2-0V	0 V associated with Fuse 2/2
T3-5	Output from Fuse 1/3	T3-0V	0 V associated with Fuse 1/3
T3-6	Output from Fuse 2/3	T3-0V	0 V associated with Fuse 2/3
T4-7	Output from Fuse 1/4	T4-0V	0 V associated with Fuse 1/4
T4-8	Output from Fuse 2/4	T4-0V	0 V associated with Fuse 2/4
T5-9	Output from Fuse 1/5	T5-0V	0 V associated with Fuse 1/5
T5-10	Output from Fuse 2/5	T5-0V	0 V associated with Fuse 2/5
T6-11	Output from Fuse 1/6	T6-0V	0 V associated with Fuse 1/6
T6-12	Output from Fuse 2/6	T6-0V	0 V associated with Fuse 2/6
T7-13	Output from Fuse 1/7	T7-0V	0 V associated with Fuse 1/7
T7-14	Output from Fuse 2/7	T7-0V	0 V associated with Fuse 2/7
T11-15	Output from Fuse 1/8	T11-0V	0 V associated with Fuse 1/8
T11-16	Output from Fuse 2/8	T11-0V	0 V associated with Fuse 2/8
T12-17	Output from Fuse 1/9	T12-0V	0 V associated with Fuse 1/9
T12-18	Output from Fuse 2/9	T12-0V	0 V associated with Fuse 2/9
T13-19	Output from Fuse 1/10	T13-0V	0 V associated with Fuse 1/10
T13-20	Output from Fuse 2/10	T13-0V	0 V associated with Fuse 2/10

Terminal	Description	Terminal	Description
T14-21	Output from Fuse 1/11	T14-0V	0 V associated with Fuse 1/11
T14-22	Output from Fuse 2/11	T14-0V	0 V associated with Fuse 2/11
T15-23	Output from Fuse 1/12	T15-0V	0 V associated with Fuse 1/12
T15-24	Output from Fuse 2/12	T15-0V	0 V associated with Fuse 2/12
T16-25	Output from Fuse 1/13	T16-0V	0 V associated with Fuse 1/13
T16-26	Output from Fuse 2/13	T16-0V	0 V associated with Fuse 2/13
T17-27	Output from Fuse 1/14	T17-0V	0 V associated with Fuse 1/14
T17-28	Output from Fuse 2/14	T17-0V	0 V associated with Fuse 2/14
T18-29	Output from Fuse 1/15	T18-0V	0 V associated with Fuse 1/15
T18-30	Output from Fuse 2/15	T18-0V	0 V associated with Fuse 2/15
T10-11	Volt-free fuse fail contact (moving pole)	T10-14	Volt-free fuse fail contact

Table 2 Terminal Connections

## 7. Specifications

Voltage Range	22–30 Vdc or 43–60 Vdc (link selectable)
Supply Current	23 A max
Fuse Outputs	30-off 3.1 5A fast blow 5x20 mm cartridge arranged in two banks of 15
Max Relay Contact Switching Voltage	60 Vdc or 125 Vac
Max Relay Contact Switching Current	0.5 A
Input Connection	LU10.16 screw clamp terminal
Input Connection Conductor Clamping Range	0.5 mm <sup>2</sup> to 16 mm <sup>2</sup>
Output Connector	BLZ two-part terminal
Output Connector Conductor Clamping Range	0.5 mm <sup>2</sup> to 2.5 mm <sup>2</sup>
Operating Temperature	0 °C to +60 °C (+32 °F to +140 °F)
Non-operating Temperature	-25 °C to +70 °C (-13 °F to +158 °F)
Relative Humidity range (operating, storage & transport)	10 % – 95 %, non-condensing
Environmental Specifications	<a href="#">Refer to document 552517</a>
<b>Dimensions</b>	
Height	79 mm (3.1 in)
Width	285 mm (11.2 in)
Depth	109 mm (4.3 in)
Weight	576 g (1.3 lb)